

TECHNICAL SPECIFICATIONS	
OVERALL DIMENSIONS (W - D - H)	850 - 1035 - 1130 mm
DIMENSIONS WITH PALLET (W - D - H)	910 - 1090 - 1295 mm
WEIGHT	140,4 Kg
MAXIMUM LOAD PER TRAY 600x400mm	2 kg
MAXIMUM LOAD PER TRAY GN1/1	4 kg
CONVECTION HEATING ELEMENTS	3x 5 kW
MAXIMUM POWER RATING	15,5 kW
ELECTRICAL INSULATION CLASS	I
HOUSING PROTECTION RATING	IPX4
WATER PRESSURE	100-200 kPa
SUPPLY VOLTAGE	380/400V 3N
FREQUENCY	50 / 60 Hz
POWER SUPPLY CABLE TYPE	H07RN-F
POWER SUPPLY CABLE SECTION:	5G 4
POWER CORD CONNECTION:	Y

CARATTERISTICHE TECNICHE	
DIMENSIONI DI INGOMBRO (L - P - H)	850 - 1035 - 1130 mm
DIMENSIONI CON PALLET (L - P - H)	910 - 1090 - 1295 mm
PESO	140,4 kg
CARICO MASSIMO PER TEGLIA 600x400mm	2 kg
CARICO MASSIMO PER TEGLIA GN1/1	4 kg
POTENZA RESISTENZE CONVEZIONE	3x 5 kW
POTENZA ELETTRICA MAX	15,5 kW
CLASSE ISOLAMENTO ELETTRICO	I
GRADO DI PROTEZIONE INVOLUCRO	IPX4
PRESSIONE ACQUA	100-200 kPa
TENSIONE DI ALIMENTAZIONE	380/400V 3N
FREQUENZA DI ALIMENTAZIONE	50 / 60 Hz
TIPO CAVO DI ALIMENTAZIONE	H07RN-F
SEZIONE CAVO DI ALIMENTAZIONE	5G 4
ALLACCIAMENTO CAVO DI ALIMENTAZIONE	Y

CARACTÉRISTIQUES TECHNIQUES	
DIMENSIONS D'ENCOMBREMENT (L - P - A)	850 - 1035 - 1130 mm
DIMENSIONS AVEC PALETTE (L - P - A)	910 - 1090 - 1295 mm
POIDS	140,4 kg
CHARGE MAXIMUM PER PLAT 600x400mm	2 kg
CHARGE MAXIMUM PER PLAT GN1/1	4 kg
PUISSANCE RÉISTANCES DE CONVECTION	3x 5 kW
PUISSANCE ÉLECTRIQUE MAXIMALE	15,5 kW
CLASSE D'ISOLATION ÉLECTRIQUE	I
INDICE DE PROTECTION DU REVÊTEMENT	IPX4
PRESSION DE L'EAU	100-200 kPa
TENSION D'ALIMENTATION	380/400V 3N
FREQUENCE D'ALIMENTATION	50 / 60 Hz
TYPE DE CABLE D'ALIMENTATION	H07RN-F
SECTION DU CABLE D'ALIMENTATION	5G 4
BRANCHEMENT DU CÂBLE D'ALIMENTATION	Y

CARACTERÍSTICAS TÉCNICAS	
MEDIDAS EXTERIORES MÁXIMAS (A - A - P)	850 - 1035 - 1130 mm
DIMENSIONES CON PALETA (A - A - P)	910 - 1090 - 1295 mm
PESO	140,4 Kg
CARGA MÁXIMA POR BANDEJA 600x400mm	2 kg
CARGA MÁXIMA POR BANDEJA GN1/1	4 kg
POTENCIA RESISTENCIAS CONVECCIÓN	3x 5 kW
POTENCIA ELÉCTRICA MÁXIMA	15,5 kW
CLASE DE AISLAMIENTO ELÉCTRICO	I
GRADO DE PROTECCIÓN CUERPO EXTERIOR	IPX4
PRESIÓN AGUA	100-200 kPa
TENSIÓN DE ALIMENTACIÓN	380/400V 3N
FRECUENCIA DE ALIMENTACIÓN	50 / 60 Hz
TIPO DE CABLE DE ALIMENTACIÓN	H07RN-F
SECCIÓN DEL CABLE DE ALIMENTACIÓN	5G 4
CONEXIÓN DEL CABLE DE ALIMENTACIÓN	Y

TECHNISCHE MERKMALE	
GESAMTABMESSUNGEN (B - T - H)	850 - 1035 - 1130 mm
ABMESSUNGEN MIT PALETTE (B - T - H)	910 - 1090 - 1295 mm
GEWICHT	140,4 Kg
HÖCHSTBLECHBELASTUNG 600x400mm	2 kg
HÖCHSTBLECHBELASTUNG GN1/1	4 kg
LEISTUNG KONVEKTION-HEIZELEMENTE	3x 5 kW
MAX. ELEKTRISCHE LEISTUNG	15,5 kW
STROMISOLIERUNGSKLASSE	I
VERKLEIDUNGSSCHUTZGRAD	IPX4
WASSERDRUCK	100-200 kPa
ANSCHLUSSPANNUNG	380/400V 3N
BETRIEBSFREQUENZ	50 / 60 Hz
ZULEITUNGSKABELTYP	H07RN-F
NETZKABEL QUERSCHNITT	5G 4
ANSCHLUSS DES STROMKABELS	Y

	850 - 1035 - 1130 mm
	910 - 1090 - 1295 mm
	140,4 Kg
600x400mm	2 kg
GN1/1	4 kg
	3x 5 kW
	15,5 kW
	I
	IPX4
	100-200 kPa
	380/400V 3N
	50 / 60 Hz
	H07RN-F
	5G 4
	Y

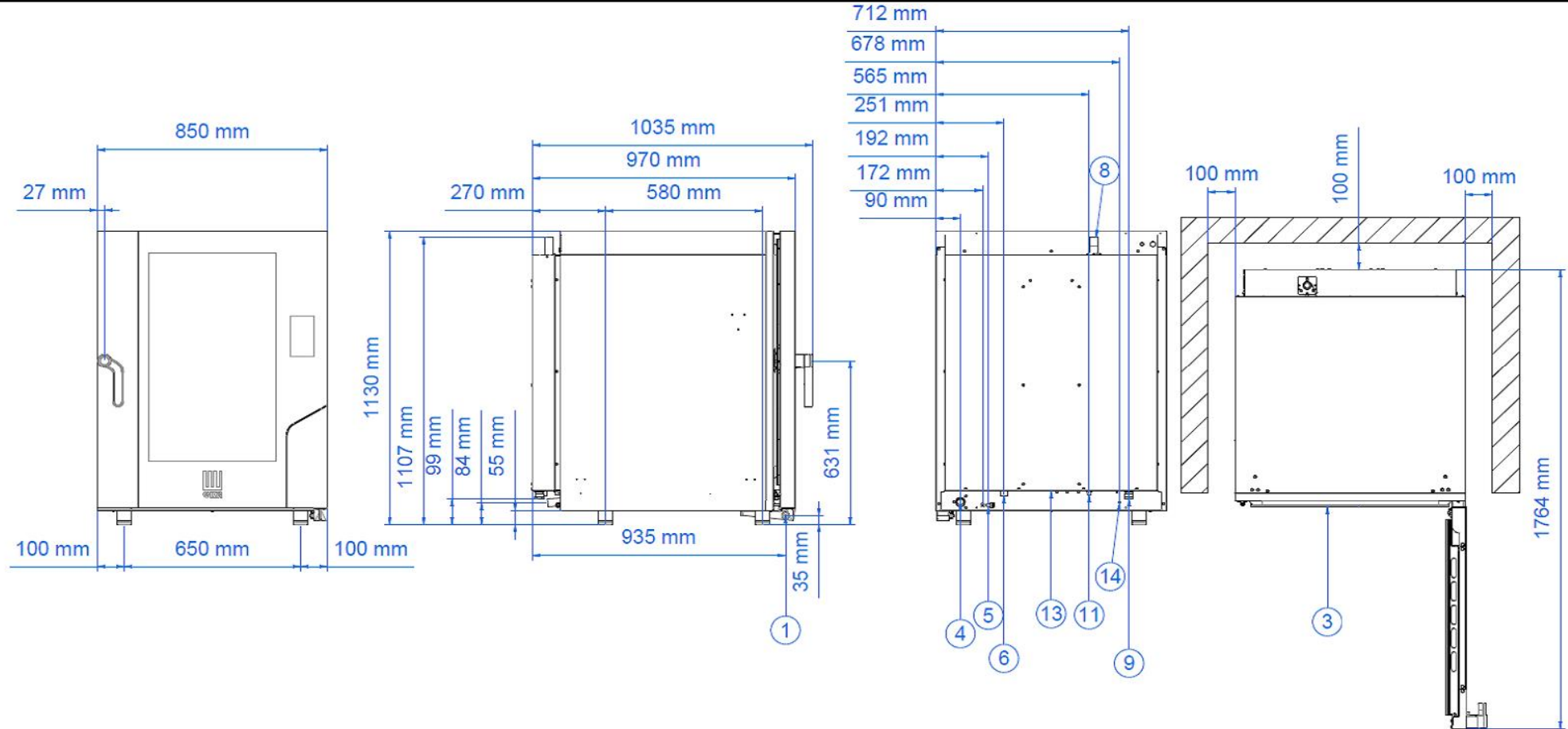

	DRAWINGS	DISEGNI	DESSINS	DIBUJOS	ZEICHNUNGEN	
1	USB PORT	PRESA USB	PRISE USB	PUERTO USB	USB-ANSCHLUSS	USB
3	SOCKET FOR CORE PROBE CONNECTION	PRESA SONDA CUORE	PRISE DE BRANCHEMENT SONDE AU COEUR	TOMA PARA CONEXIÓN DE LA SONDA AL CORAZÓN	ANSCHLUSS FÜR KERNFÜHLER	
4	WATER OULET TUBE (DN 30)	TUBO SCARICO ACQUA (DN 30)	TUYAU D'ÉVACUATION DE L'EAU (DN 30)	TUBO PARA DESAGUE (DN 30)	WASSERAUSLASSROHR (DN 30)	( 30)
5	CLEANING SYSTEM WATER INLET	INGRESSO ACQUA LAVAGGIO	ENTRÉE D'EAU DE LAVAGE	ENTRADA AGUA LAVADO	EINGANG REINIGUNGSWASSER	
6	SOFTENED WATER INLET 3/4"	INGRESSO ACQUA ADDOLCITA 3/4"	ENTRÉE D'EAU ADOUCI 3/4 "	ENTRADA AGUA ABLANDADA 3/4"	EINGANGS WEICHWASSER 3/4"	3/4"
8	STEAM EXHAUST	SFIATO VAPORE	EVACUATION DE VAPEUR	SALIDA DEL VAPOR	DAMPFAUSLASS	
9	CABLE GLAND FOR POWER SUPPLY	PRESSACAVO ALIMENTAZIONE ELETTRICA	PRESSE CABLE ALIMENTATION	PRENSAESTOPAS ELECTRICIDAD	KABELHALTER STROMVERSORGUNG	
11	SAFETY THERMOSTAT	TERMOSTATO SICUREZZA	THERMOSTAT DE SÉCURITÉ	TERMOSTATO DE SEGURIDAD	SICHERHEITSTHERMOSTAT	
13	COOLING AIR OUTLET	USCITA ARIA RAFFREDDAMENTO	SORTIE D'AIR DE REFRROIDISSEMENT	SALIDA DE AIRE DE REFRIGERACIÓN	KÜHLLUFTAUSLASS	
14	EQUIPOTENTIAL CLAMP	MORSETTO EQUIPOTENZIALE	PINCE ÉQUIPOTENTIELLE	ABRAZADERA EQUIPOTENCIAL	ÄQUIPOTENTIALKLEMME	



	WIRING LAYOUTS	SCHEMA ELETTRICO	SCHÉMAS ÉLECTRIQUES	ESQUEMAS ELÉCTRICOS	SCHALTPLÄNE	
M	POWER SUPPLY TERMINAL BOARD	MORSETTIERA ALIMENTAZIONE	BORNIER ALIMENTATION	CAJA DE CONEXIONES DE ALIMENTACIÓN	VERSORGUNGSKLEMMLEISTE	
B	CONTACTOR COIL	BOBINE TELERUTTORI	BOBINE TÉLÉRUPTEUR	BOBINAS TELERUPTORES	SCHÜTZSPULEN	
TR	CONTACTOR	TELERUTTORI	TÉLÉRUPTEUR	TELERUPTORES	SCHÜTZS	
R1-2-3	CIRCULAR HEATING ELEMENT	RESISTENZA CIRCOLARE	RECISTENCE CIRCULAIRE	RESISTENCIA CIRCULAR	KREIS HEIZELEMENT	
C	CAPACITOR	CONDENSATORE	CONDENSATEUR	CONDENSADOR	KONDENSATOR	
MR	RADIAL MOTORISED VENTILATOR	MOTOVENTILATORE RADIALE	MOTOVENTILATEUR RADIAUX	MOTOVENTILADOR RADIAL	RADIAL MOTORLÜFTER	
MT	TANGENTIAL MOTORISED VENTILATOR	MOTOVENTILATORE TANGENZIALE	MOTOVENTILATEUR TANGENTIEL	MOTOVENTILADOR TANGENCIAL	TANGENZIALER MOTORLÜFTER	
EL	WASHING SOLENOID VALVE	ELETTROVALVOLA LAVAGGIO	ELECTROVANNE DE LAVAGE	VÁLVULA SOLENOIDE DE LAVADO	WASCHEN MAGNETVENTIL	
PL	WASHING PUMP	POMPA LAVAGGIO	POMPE DE LAVAGE	BOMBA DE LAVADO	WASCHPUMPE	
MI	DOOR MICROSWITCH	MICROINTERRUTTORE PORTA	MICRO-INTERRUPTEUR PORTE	MICROINTERRUPTOR PUERTA	MIKROSWITCH TÜR	
D	DISPLAY BOARD	SCHEDA DISPLAY	PLATINE DISPLAY	TARJETA DEL DISPLAY	DISLAY PLATINE	
SMI	MICROPOWER BOARD	SCHEDA MICROPOTENZA	PLATINE MICROPUISSANCE	TARJETA MICROPOTENCIA	MICROPOWER PLATINE	
A1	LED BAR POWER SUPPLY	ALIMENTATORE BARRA LED	ALIMENTATION BARRE LED	ALIMENTACION BARRA DE LUCES LED	STROMVERSORGUNG LED LEISTE	
BL	LED BAR	BARRA LED	BARRE LED	BARRA DE LUCES LED	LED LEISTE	
A2	POWER SUPPLY BOARDS	ALIMENTATORE SCHEDE	ALIMENTATION PLATINE	ALIMENTACION TARJETAS	KARTENZUFUHR	
IO	ON/OFF	ON/OFF	ON/OFF	ON/OFF	ON/OFF	ON/OFF
T1	OVEN SAFETY THERMOSTAT	TERMOSTATO DI SICUREZZA FORNO	THERMOSTAT DE SÉCURITÉ FOUR	TERMOSTATO DE SEGURIDAD HORNO	SICHERHEITSTHERMOSTAT	
E	WATER SOLENOID-VALVE	ELETTROVALVOLA ACQUA	ELECTROVANNE EAU	ELECTROVÁLVULA AGUA	WASSER MAGNETVENTIL	
LV	CONNECTION TO PROOFER	COLLEGAMENTO LIEVITATORE	CONNEXION CHAMBRE LEVAGE	CONEXION A LA FERMENTADORA	GARSCHRANK VERBINDUNG	
CP	CONNECTION TO HOOD	COLLEGAMENTO CAPPA	CONNEXION HOTTE	CONEXION A LA CAMPANA	HAUBE VERBINDUNG	
S1	COOKING CHAMBER PROBE	SONDA CAMERA COTTURA	SONDE CHAMBRE CUISSON	SONDA DE LA CAMARA DE COCCION	KOCHKAMMER-FUEHLER	
S2	HEART PROBE	SONDA AL "CUORE"	SONDE AU COUER	SONDA AL CORAZON	KERNFUEHLER	